

NOTICE DE MONTAGE-ASSEMBLY INSTRUCTIONS- MONTAGEANLEITUNG- MANUAL DE MONTAJE- MANUAL DE MONTAGEM

creador
inspired by nature

SET VERO

Code: 544109

Ensemble de 4 pièces
FRS71257+FRS71257L+FTS71310

BIEN ETUDIER LA NOTICE DE MONTAGE
REPEREZ LES PIECES CONSTITUANT VOTRE
MEUBLE
REGROUPEZ ET CONTROLEZ LA QUINCAILLERIE
MUNISSEZ-VOUS DE L'OUTILLAGE NECESSAIRE
AMENAGEZ-VOUS UNE ZONE DE MONTAGE
PROCEDEZ AU MONTAGE
NE JAMAIS FORCER LES ASSEMBLAGES
RESSERREZ LES VIS APRES QUELQUES TEMPS
D'USAGE
GARDER VOTRE NOTICE DE MONTAGE, SI UNE PIECE
VENAIT A MANQUER, ELLE SERAIT LE
PLUS CLAIR MOYEN DE COMMUNIQUER AVEC
VOTRE MAGASIN.

READ THE ASSEMBLY INSTRUCTIONS CAREFULLY
IDENTIFY THE ELEMENTS CONSTITUING YOUR
PIECE OF FURNITURE
GROUP AND CHECK THE HARDWARE FITTINGS
GET THE TOOLS NEEDED
CLEAR SPACE TO WORK
PROCEED TO ASSEMBLE
NEVER FORCE THE FITTINGS
TIGHTEN THE SCREW AFTER USING FOR
SOMETIME
KEEP YOUR ASSEMBLY INSTRUCTIONS.IT
COULD HELP FOR BETTER COMMUNICATION
WITH YOUR STORE, IN THE EVENT OF QUERY.

DIE MONTAGEANLEITUNG SORGFÄLTIG DURCHLESEN
DIE EINZELTEILE DES MÖBELSTÜCKS ERMITTELN
DIE BESCHLÄGE ZUSAMMENLEGEN UND PRÜFEN
DAS NOTWENDIGE WERKZEUG ZURECHTLEGEN
EINEN MONTAGEBEREICH FREIMACHEN
DAS MÖBELSTÜCK ZUSAMMENBAUEN
NIEMALS DIE VERBINDUNGEN ZU STARK ANZIEHEN
DIE SCHRAUBEN NACH EINIGER ZEIT DES
GEBRAUCHS ERNEUT FESTZIEHEN
DIE MONTAGEANLEITUNG GUT AUFBEWAHREN:
SOLLTE EIN TEIL FEHLEN, IST SIE DAS BESTE
VERSTÄNDIGUNGSMITTEL MIT IHREM GESCHÄFT





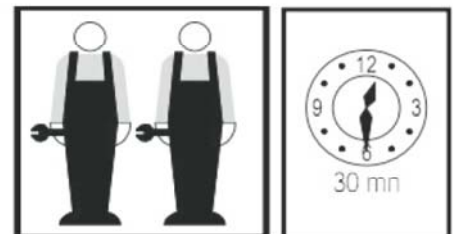
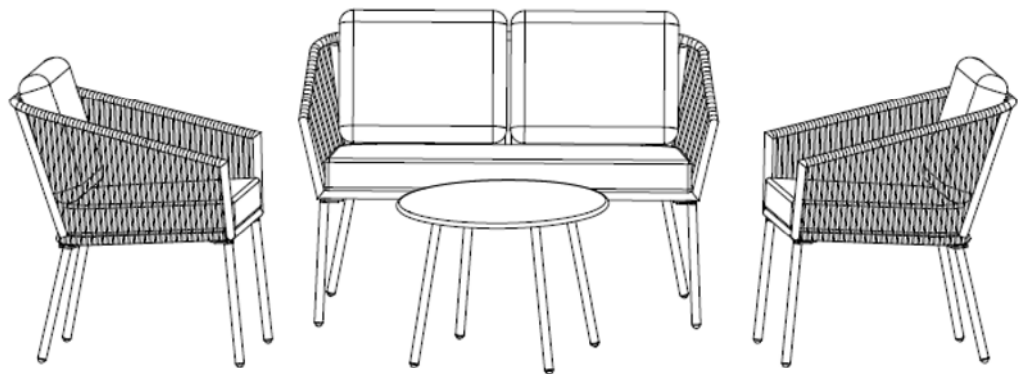



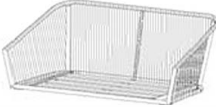

ESTUDIE ATENTAMENTE EL MANUAL DE
MONTAJE
LOCALICE LAS PIEZAS QUE CONSTITUYEN SU
MUEBLE
REUNA Y CONTROLE LOS TORNILLOS
EQUIPE-SE DE LAS HERRAMIENTAS
NECESARIAS
PREPARE UMA ZONA DE MONTAJE
REALICE EL MONTAJE
NO FUERCE NUNCA EN LAS UNIONES
APRIETE LOS TORNILLOS DESPUES DE CIERTO
TIEMPO DE UTILIZACION
CONSERVE SU MANUAL DE MONTAJE, SI
FALTARA UNA PIEZA, SERIA LA MANERA MAS
FACIL DE COMUNICAR CON LA TIENDA

LEIA ATENTAMENTE O MANUAL DE INSTALAÇÃO
IDENTIFICAR OS ELEMENTOS ESTÃO SEUS MÓVEIS
AGRUPE E VERIFIQUE OS PARAFUSOS
EQUIPE-SE DAS FERRAMENTAS NECESSÁRIAS
PREPARAR UMA ÁREA DE MONTAGEM
REALIZE O MONTAGEM
NUNCA FORCE NAS UNIÕES
APERTAR DEPOIS DE ALGUM TEMPO DO USO
GUARDE AS INSTRUÇÕES. SE FALTA UMA PEÇA A
MANEIRA MAIS FÁCIL ES COMUNICAR A LOJA



Acier/ Polyester

LISTE DES PIECES

A		2
B		1
C		6
D		6
E		1
F		4
G	 M6 x 15MM	38
H		4
I		2
J		1
K		1

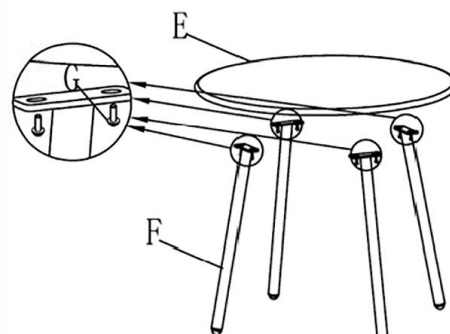
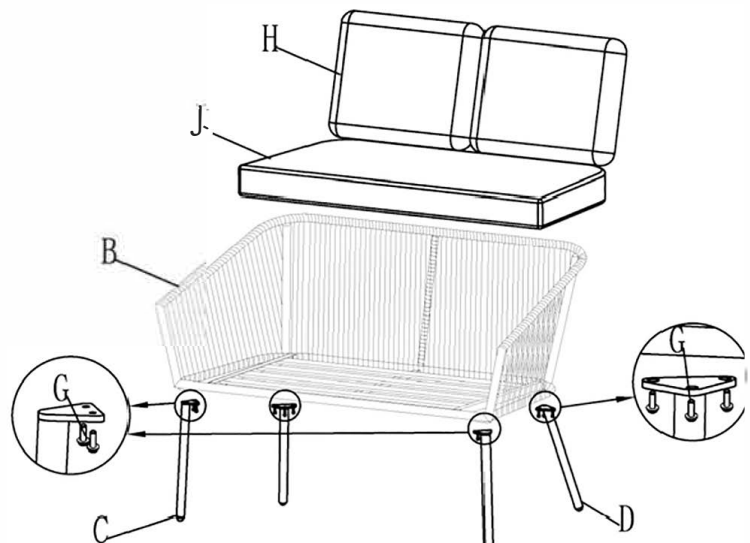
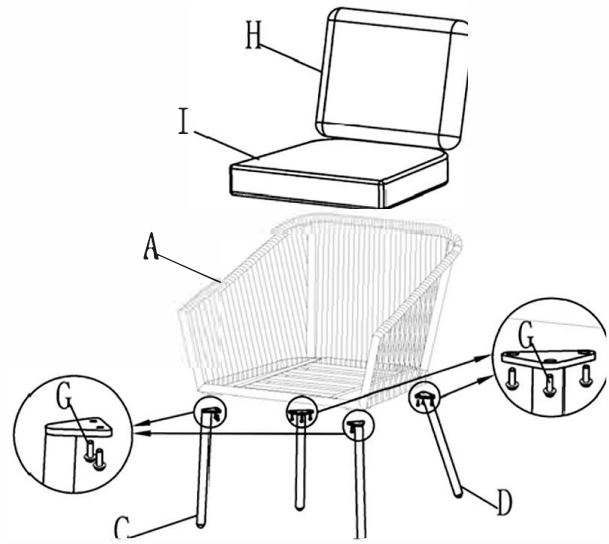

Step/étape 1

FRS71257

1.1



A×1



C×2



D×2



G×10
(M6×15MM)

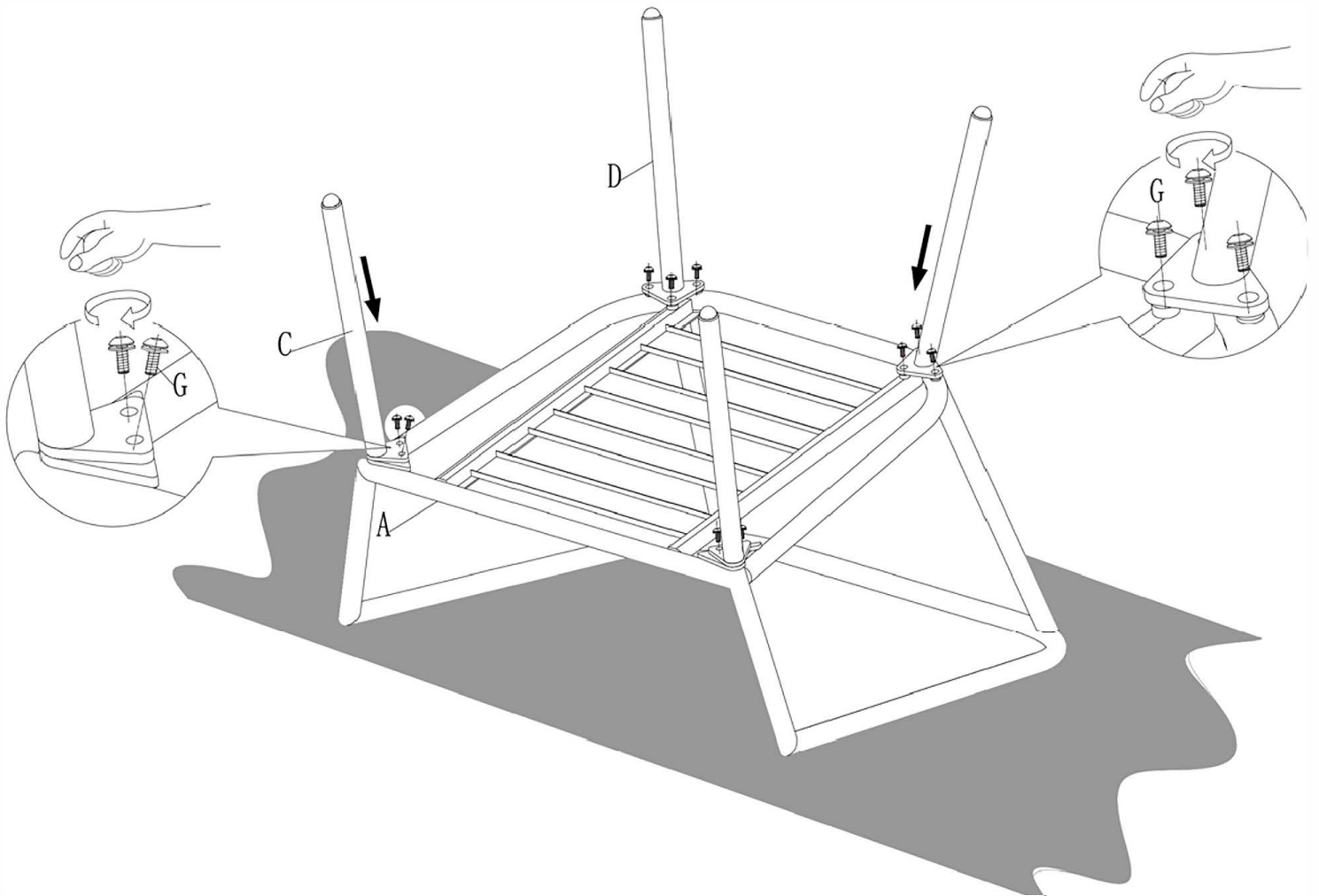

1.2



K×1

Serrer toutes
les vis.

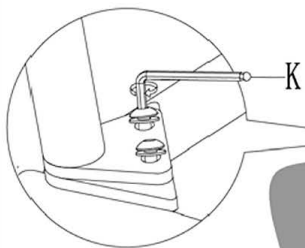

Serrer toutes les
vis.

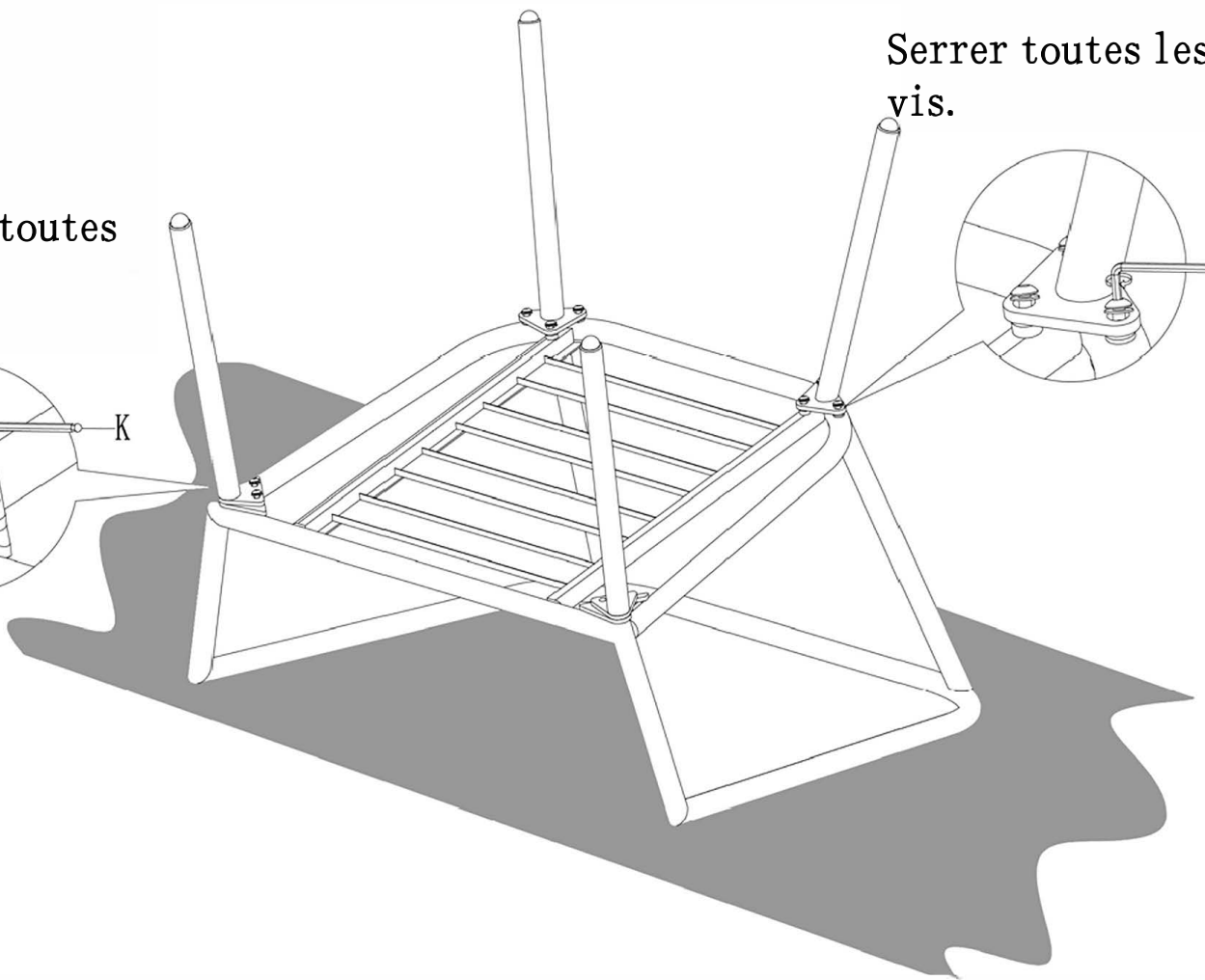
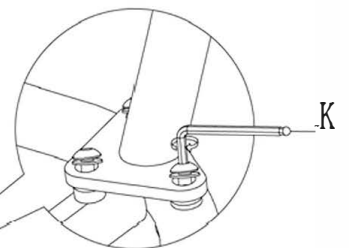

1.3

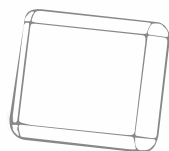

Hx1



Ix1

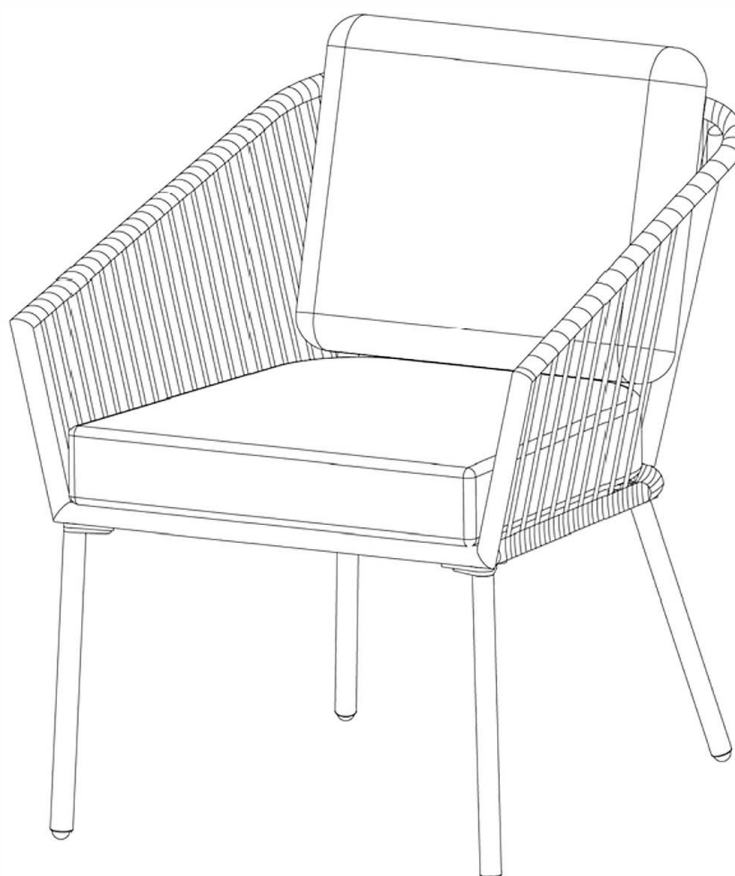

Step/étape 4

FRS71257L

1.1

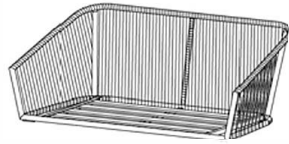

B×1



C×2



D×2



G×10
(M6×15MM)

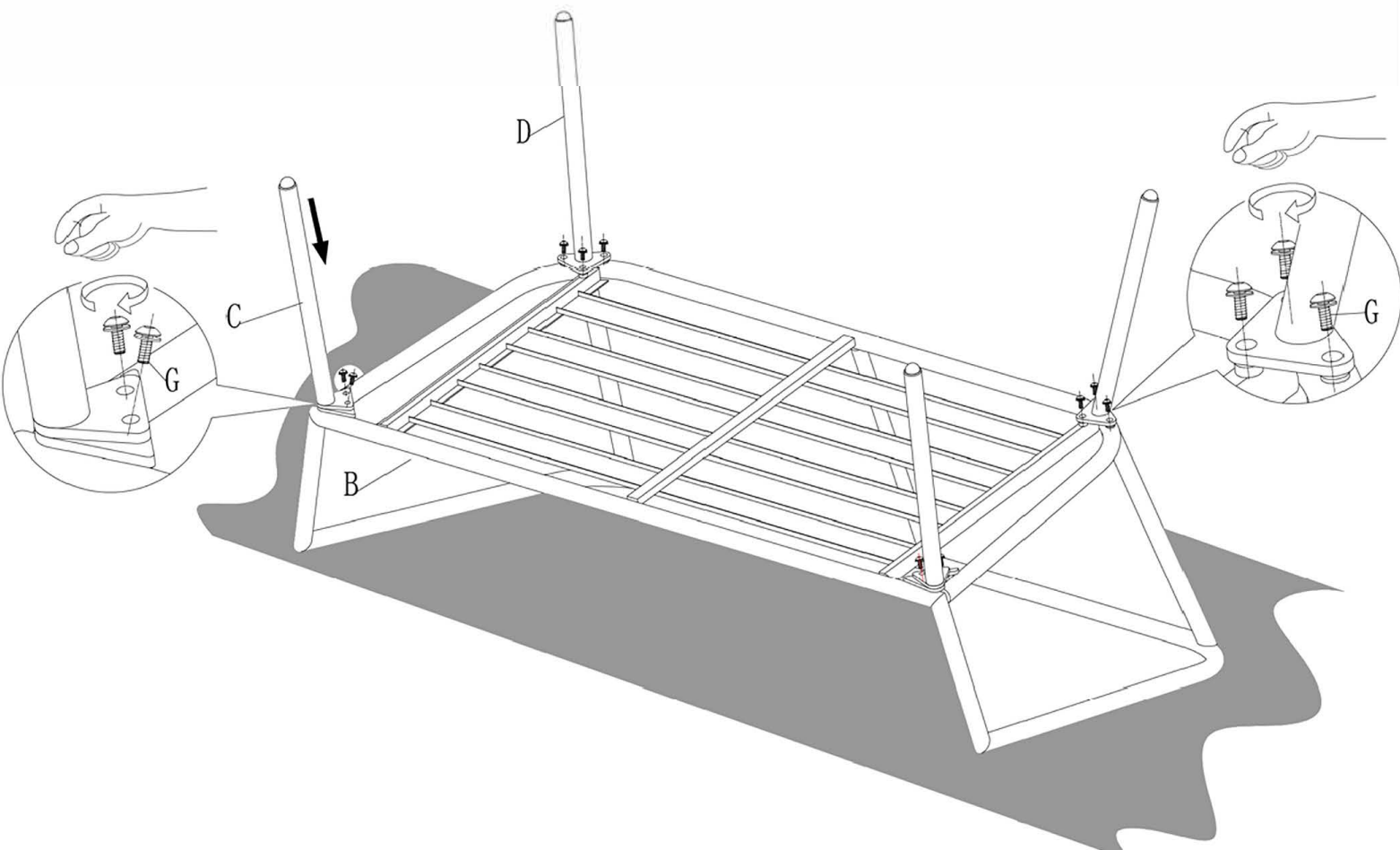

1.2



K×1

Serrer toutes les vis.

Serrer toutes les vis.

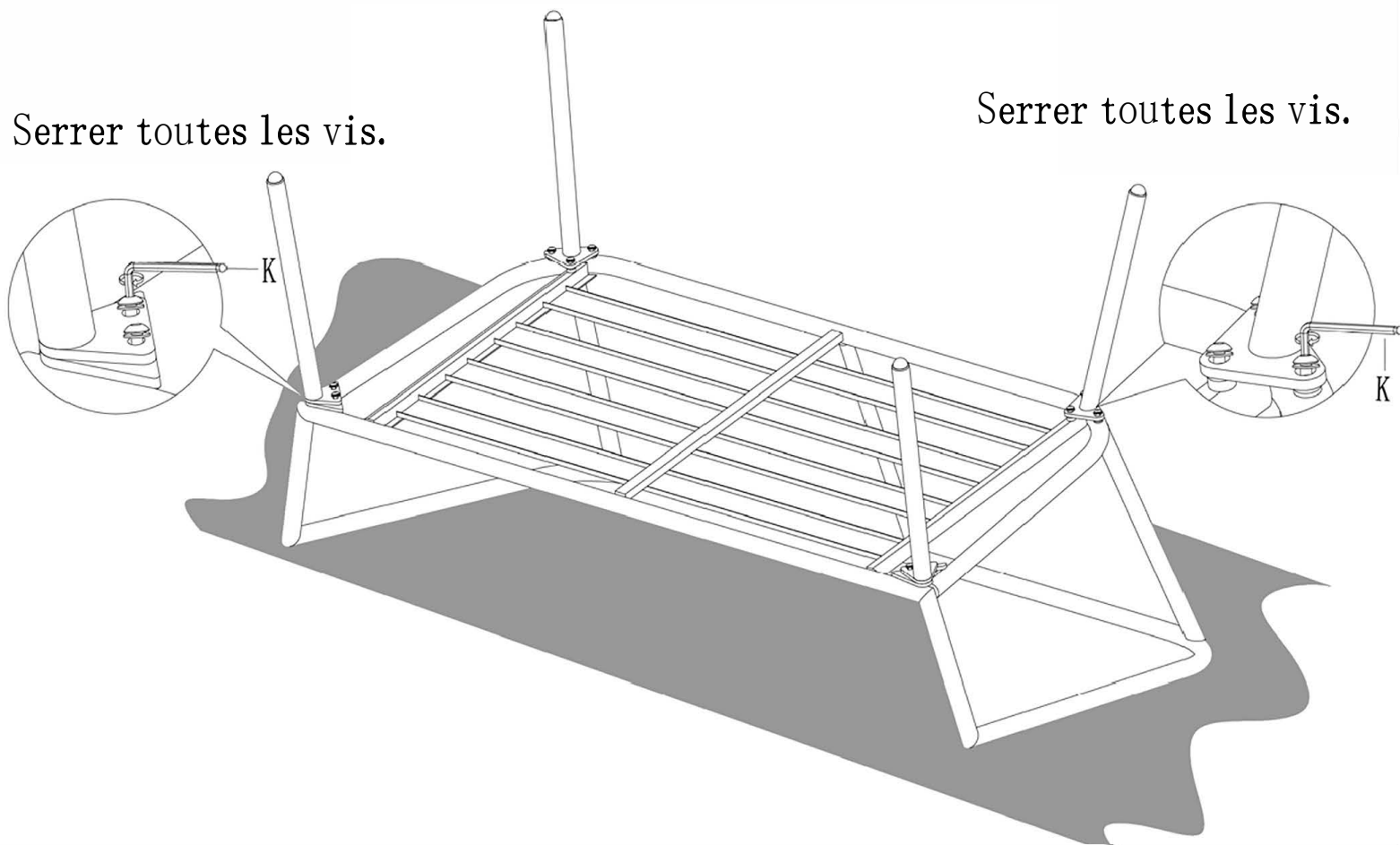

1.3



H×2



J×1

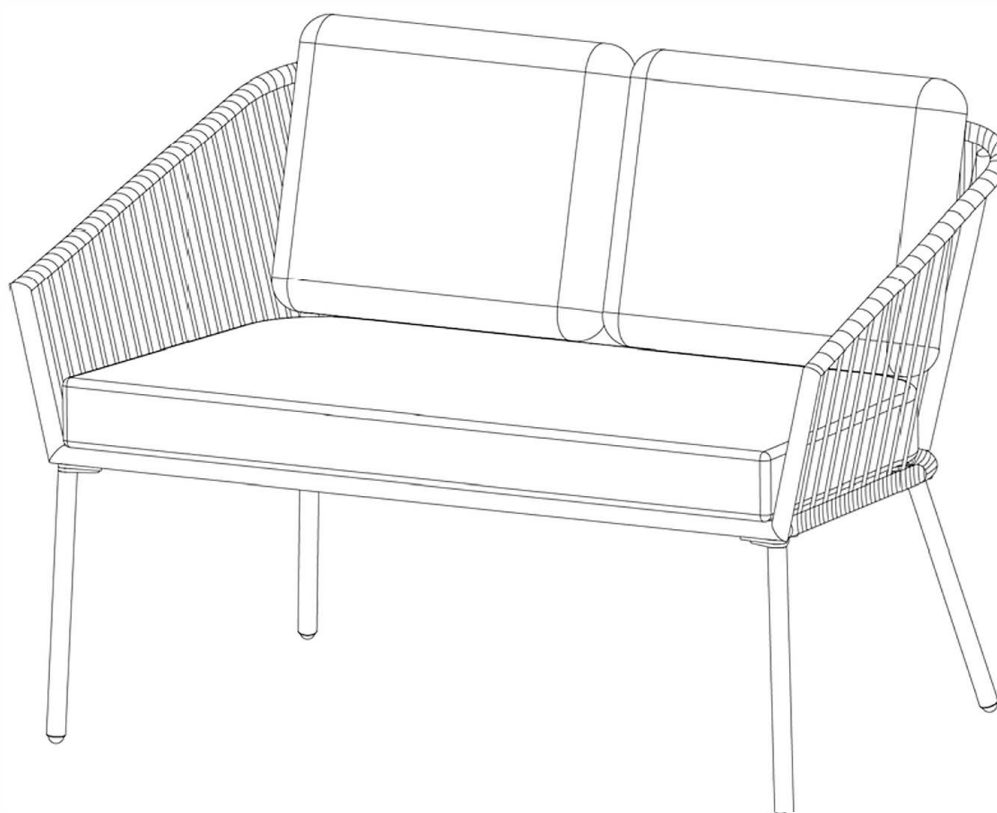

1.1



E×1



F×4

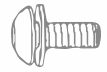

G×8
(M6×15MM)

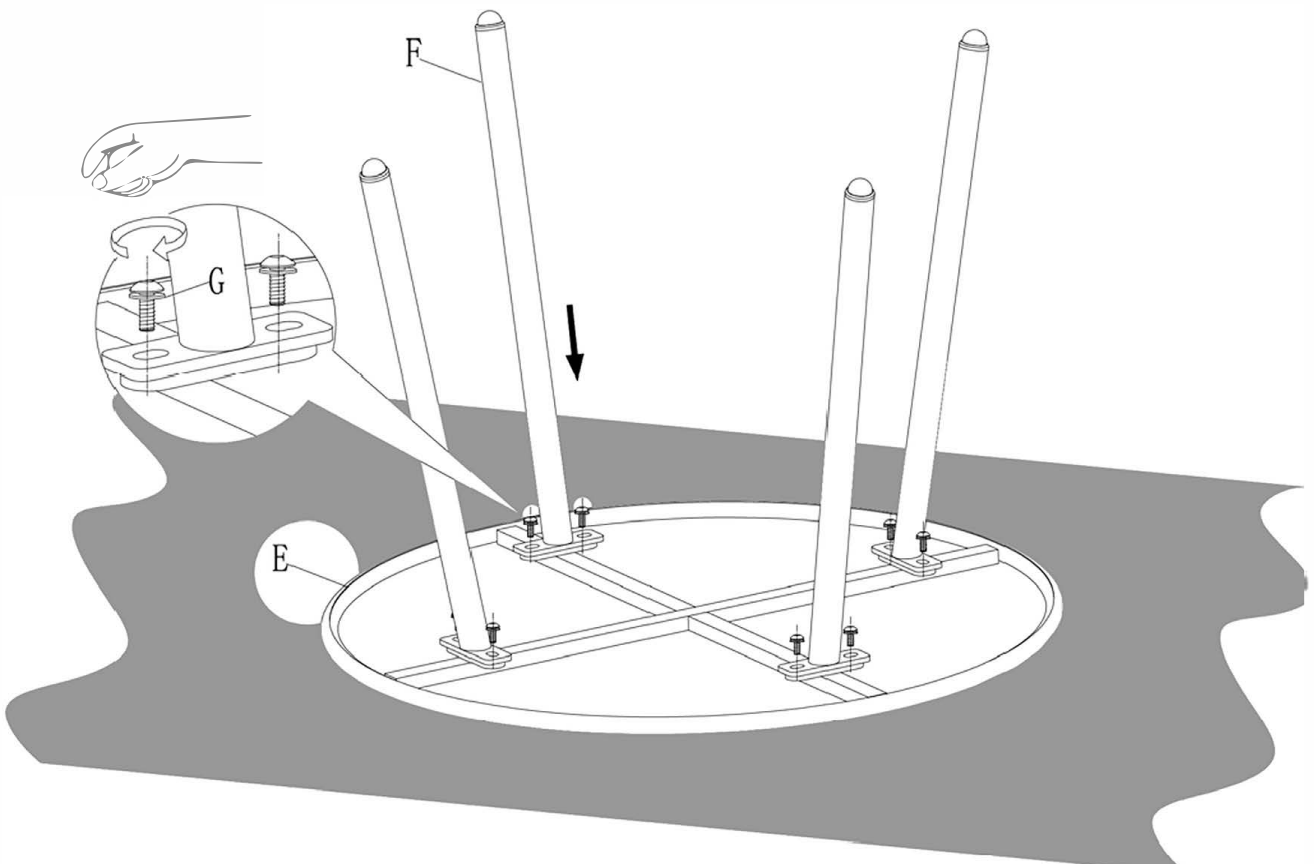

1.2



K×1

Serrer toutes les vis.

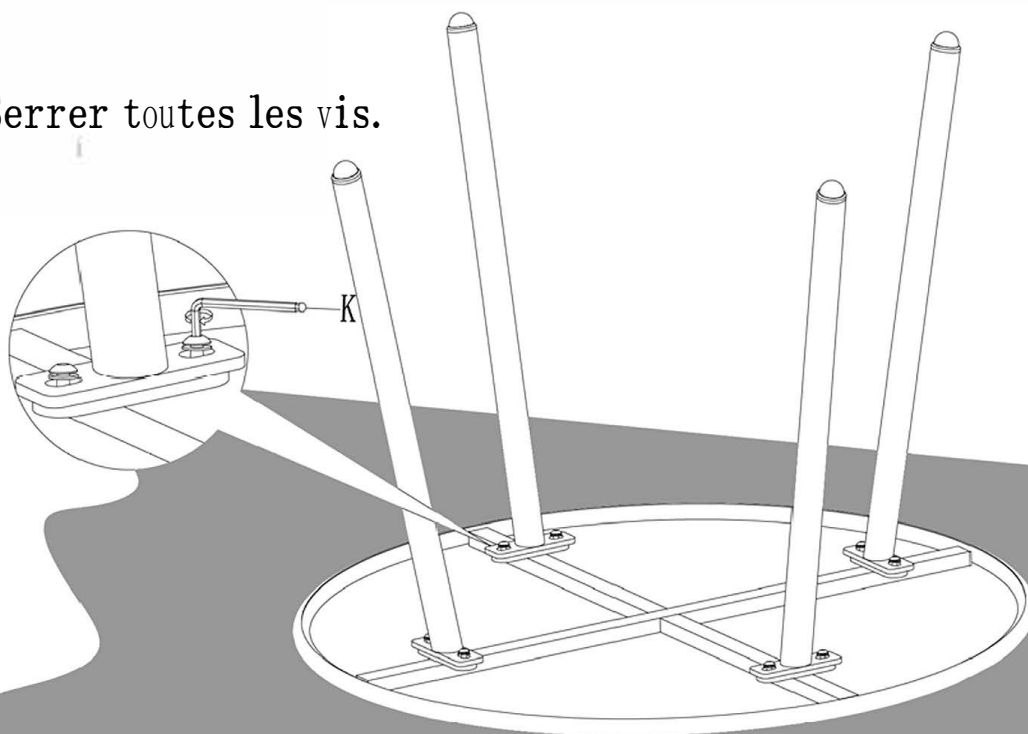

REMERCIEMENTS

Vous avez choisi d'acheter ce produit chez CREADOR. Nous espérons que vous en serez entièrement satisfait et vous remercions de votre confiance.

Si toutefois vous aviez remarqué un problème en cours de montage, appelez vite votre magasin qui vous apportera la solution adéquate.

Vous pouvez également nous écrire à l'adresse suivante :

WITH THANKS

You have decided to buy a product from CREADOR. We thank you for your trust and hope you are fully satisfied with your purchase.

If for any reason you encounter a problem when assembling this item, quickly call your shop which will provide you with a suitable solution.

You can also contact us at the following address :

DANKE

Sie haben beschlossen, dieses Produkt bei CREADOR zu kaufen. Wir hoffen, daß es Sie vollauf zufriedenstellt und danken Ihnen für Ihr Vertrauen.

Sollten Sie jedoch während der Montage auf ein Problem gestoßen sein, rufen Sie bitte schnell unser Geschäft an, das Ihnen die passende Lösung bringt.

Sie können uns auch unter folgender Adresse schreiben:

AGRADECIMIENTOS

Usted ha escogido comprar este producto en CREADOR. Esperamos que esté completamente satisfecho de eso y le agradecemos su confianza.

No obstante, si usted hubiese observado algún problema durante el montaje, lláme rápido a su tienda, ésta le dará la solución adecuada.

También puede escribirnos a la siguiente dirección :

AGRADECIMIENTOS

Você optou por comprar este produto CREADOR. Esperamos que você esteja completamente satisfeito com isso e agradecemos a sua confiança.

No entanto, se você tivesse visto algum problema durante a instalação, chame rápido a sua loja, ele vai te dar a solução certa.

Você também pode escrever para o seguinte endereço:

<p>"Utilisation domestique uniquement"</p>	<p>A nettoyer à l'eau 30°C maximum et au savon à la main Laisser sécher à l'ombre et à stocker dans un endroit sec et ventilé à l'abri A positionner sur un sol plat</p>	<p>"A monter soi même"</p>
<p>For domestic use only</p>	<p>Clean by hand with water and mild soap with a maximum temperature of 30°C Leave to dry in the shade and store in a dry and ventilated place during winter Position in a stable way on a flat ground</p>	<p>Easy self-assembly</p>
<p>Nur für den Hausgebrauch bestimmt.</p>	<p>Bitte mit einer milden Seifenlauge und einer Höchsttemperatur von 30°C reinigen. Bitte im Schatten trocknen lassen und den Winter über in einem trockenen Platz aufbewahren. Vor Gebrauch auf einem festen Grund aufstellen</p>	<p>Einfache Selbstmontage</p>
<p>Alleen voor thuisgebruik.</p>	<p>Graag met een zachte zeep en water met een maximaal temperatuur van 30°C schoonmaken en in de schaduw laten drogen. Tijdens de winter maanden in een droge plaats opbergen. Voor gebruik op een vlakke grond positioneren</p>	<p>Eenvoudig zelf te monteren</p>
<p>Para uso doméstico.</p>	<p>Limpiar a mano con agua y un jabón suave a una temperatura de unos 30°C, Dejar secar en la sombra y guardar en un lugar seco y ventilado durante el invierno. Colocar de una manera estable en una superficie plana</p>	<p>Montaje sencillo</p>
<p>Para uso doméstico</p>	<p>Limpe a mão com sabão neutro e água a uma temperatura de cerca de 30°C. Deixe secar à sombra e armazenar em local seco e ventilado durante o inverno. Coloque em uma forma estável em um superfície plana</p>	<p>Montaje sencillo</p>

Importé par
MWH GMBH
Blindeisenweg 23
41468 Neuss
Allemagne
SAV France : sav.creador@mwhgmbh.de
SAV Germany: info@mwhgmbh.de
Merci de joindre une photo et la facture d'achat



A CONSERVER POUR LECTURE ULTERIEURE

GARANTIE FABRICANT 2 ANS date d'achat

Envoi de pièces détachées sur justificatif d'achat (ticket de caisse ou facture)

En cas de demande d'échange ou de casse liée au transport, veuillez contacter le revendeur

Champs d'application :

- Utilisation dans les conditions normales et conformes aux conseils d'utilisation, d'entretien et dans le cadre d'un usage privatif des caractéristiques mécaniques, à l'exclusion des caractéristiques cosmétiques.
- Limite géographique : France continentale
- Exclusions : Plateaux de verre et toiles

Sav.creador@mwhgmbh.de

SAV Germany:info@mwhgmbh.de